

# Magnetic Confinement Demonstration: Motion of Charged Particles in a Magnetic Field

Part of a Series of Activities in Plasma/Fusion Physics  
to Accompany the chart  
*Fusion: Physics of a Fundamental Energy Source*

**Robert Reiland, Shady Side Academy, Pittsburgh, PA**

Chair, Plasma Activities Development Committee of the  
Contemporary Physics Education Project (CPEP)

**Editorial assistance:** G. Samuel Lightner, Westminster College, New Wilmington, PA and  
Vice-President of Plasma/Fusion Division of CPEP

**Advice and assistance:** T. P. Zaleskiewicz, University of Pittsburgh at Greensburg,  
Greensburg, PA and President of CPEP

Prepared with support from the Department of Energy, Office of Fusion Energy Sciences,  
Contract #DE-AC02-76CH03073.

## Preface

This activity is intended for use in high school and introductory college courses to supplement the topics on the Teaching Chart, *Fusion: Physics of a Fundamental Energy Source*, produced by the Contemporary Physics Education Project (CPEP). CPEP is a non-profit organization of teachers, educators, and physicists which develops materials related to the current understanding of the nature of matter and energy, incorporating the major findings of the past three decades. CPEP also sponsors many workshops for teachers. See the homepage [www.CPEPweb.org](http://www.CPEPweb.org) for more information on CPEP, its projects and the teaching materials available.

The activity packet consists of this student activity and separate notes for the teacher. The Teacher's Notes include background information, equipment information, expected results, and answers to the questions that are asked in the student activity. The student activity is self-contained so that it can be copied and distributed to students. Teachers may reproduce parts of this document for their classroom use as long as they include the title and copyright statement. Page and figure numbers in the Teacher's Notes are labeled with a T prefix, while there are no prefixes in the student activity. The page number and figures in the separate background section are labeled with a B prefix.

Developed in conjunction with the Princeton Plasma Physics Laboratory and funded through the Office of Fusion Energy Sciences, U.S. Department of Energy, this activity has been field tested at workshops with high school and college teachers.

We would like feedback on this activity. Please send any comments to:

Robert Reiland  
Shady Side Academy  
423 Fox Chapel Road  
Pittsburgh, PA 15238

e-mail: [robreiland1@comcast.net](mailto:robreiland1@comcast.net)  
voice: 412-968-3049

# Magnetic Confinement Demonstration: Motion of Charged Particles in a Magnetic Field

## Part of a Series of Activities in Plasma/Fusion Physics to Accompany the chart *Fusion: Physics of a Fundamental Energy Source*

### Procedures:

1. Turn on your oscilloscope and adjust until there is a dot on the screen. Horizontal and vertical position knobs can be used to get the dot near the center of the screen.
2. Slowly bring a bar magnet toward the screen holding it horizontally with the north pole toward the dot on the screen, and do your best to keep the magnet oriented parallel to the direction of the electron beam as the beam goes from the back of the oscilloscope to the screen (see Figure 1). Another way to think of this is that if the electron beam were to continue along a straight line out of the screen, it should pass from the north pole of the magnet through the south pole. Observe what happens to the dot as the magnet gets closer.

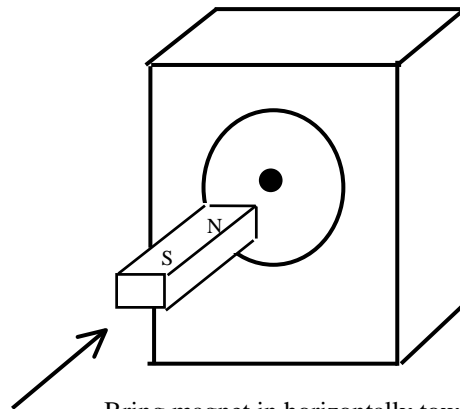

Bring magnet in horizontally toward the dot on the screen

**Figure 1:** Affect of magnetic field parallel to the motion of charges

Does the dot move around a little or a lot? Is there any systematic motion of the dot as you move the magnet in closer?

- Turn the magnet so that a horizontal line from its south pole through its north pole is perpendicular to the electron beam and the north pole is oriented as shown in Figure 2a. Move the magnet slowly toward the screen from the side.

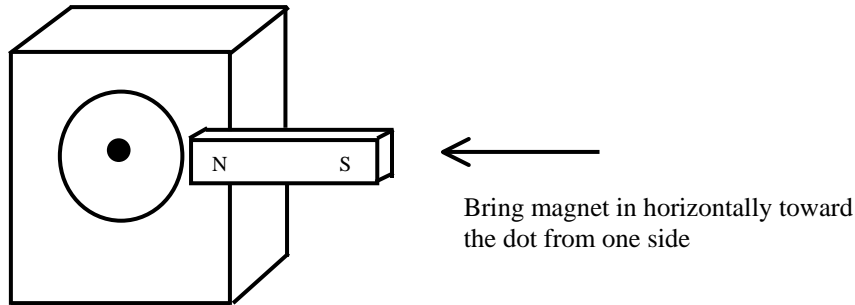

**Figure 2a:** Affect of magnetic field perpendicular to the motion of the charges with the magnet just in front of the oscilloscope to one side of the screen.

If you have an inexpensive oscilloscope, the case probably doesn't shield the electron beam from magnetic fields. You should then be able to get better results by starting the magnet at one side of the oscilloscope case, about half way from back to front. Again move the magnet toward the oscilloscope and observe the effects on the dot (see Figure 2b).

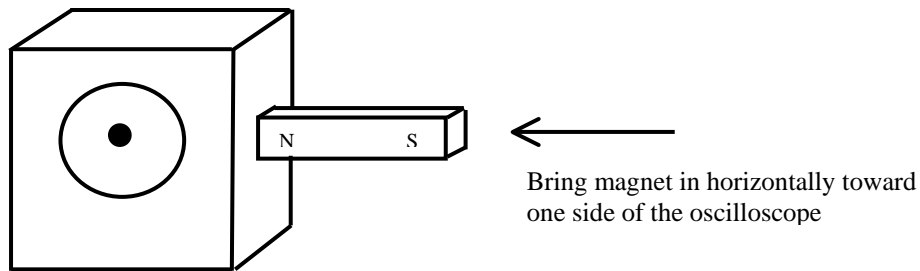
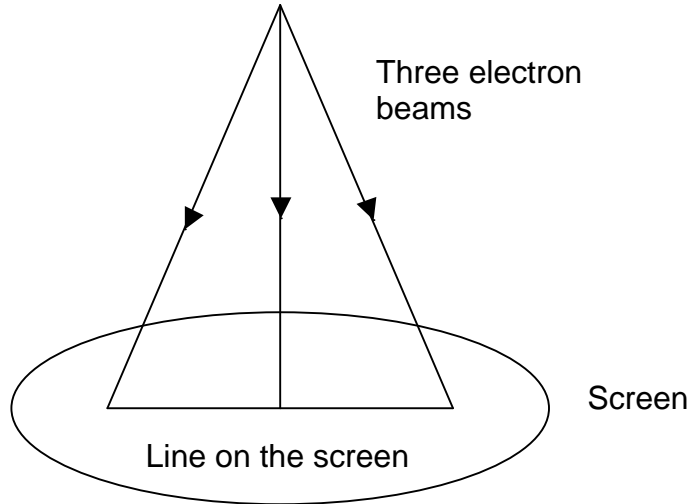

**Figure 2b:** Affect of magnetic field perpendicular to motion of the charges with the magnet at the side of the oscilloscope.

Does the dot move around a little or a lot? Is there any systematic motion of the dot as you move the magnet in closer?

- Adjust the sweep frequency and the horizontal gain until there is a straight line in the middle of the screen about half across the screen. You now have beams of charged particles (electrons) going from the back of the tube in the oscilloscope and hitting the front of the tube. The front, or screen, is the only part that you can see. It is coated with a phosphor that glows whenever struck by electrons of sufficient energy. The line you see is really an

illusion since no electron is moving across the screen. The illusion is produced by sending a set of electron beams to nearby points along the line you see so rapidly that it looks like something has drawn a solid line. If your eyes responded thousands of times faster than they do, you would see a succession of individual dots rather than the solid line. You should be able to see that this happens by adjusting the sweep frequency knob to lower and lower settings until you see a dot move from left to right over and over again. An illustration of paths of three of the many beams is shown in Figure 3.



**Figure 3:** Three electron beams striking the screen on the front of an oscilloscope. The beams on the left and right have velocity components parallel to the screen in addition to the components perpendicular to the screen.

5. Slowly bring a bar magnet toward the screen holding it horizontally with the north pole toward the center of the line on the screen (as you did in Procedure 2). Describe what happens to the line as the magnet gets closer.

6. If you have a solenoid that can be powered by a d.c. power supply, connect the solenoid to the power supply, put some iron bars inside the solenoid to increase the magnetic field that will be produced, and firmly tape them in place with duct tape to keep them from falling or magnetically surging out. Turn the power supply to about 10 volts, and move the solenoid toward the screen holding it horizontally with one end toward the screen as was done with the bar magnet in Procedure 5. Again describe what happens.

7. An alternative to Procedure 6 is to put the solenoid close to the screen in the same orientation as in Procedure 6, and smoothly increase the voltage to the power supply. In either case you are increasing the magnetic field that the electron beams are moving through.

**Questions:**

1. When you used a bar magnet in Procedure 5, did the entire line rotate together as you moved the magnet closer and closer to the screen? What does this suggest about the uniformity of the magnetic field where it acts on the electron beams?

2. If you also used a solenoid in Procedure 5, did the entire line rotate together as you moved the solenoid closer and closer to the screen or as you increased the power to the solenoid without moving it? What does this suggest about the uniformity of the magnetic field where it acts on the electron beams?

## General Background: Interaction of Charged Particles in Magnetic Fields

It is possible to partially trap charged particles, such as those in a plasma, by surrounding them with a uniform magnetic field such as is generated inside a solenoid. Because the magnetic force on each charged particle is always perpendicular to the particle's direction of motion and also perpendicular to the external magnetic field, a uniform magnetic field can produce inward forces of constant magnitude as illustrated in Figure B1.

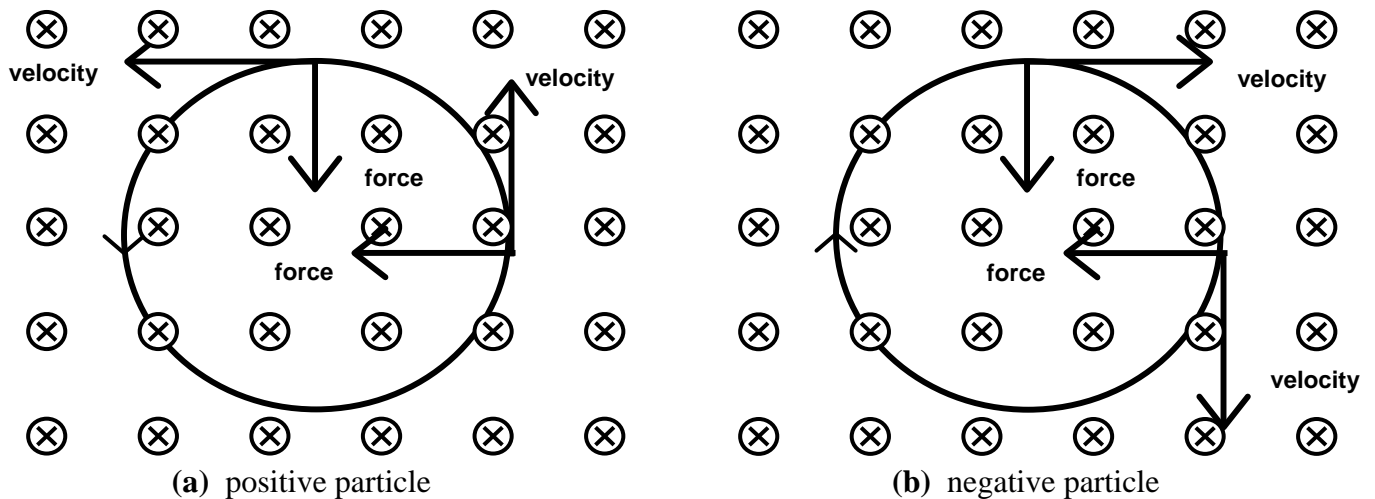

**Figure B1:** Motion of and forces on a charged particle when the particle's velocity is perpendicular to the uniform magnetic field (shown as x's into the paper) for (a) a positive particle and (b) a negative particle.

If the velocity of the particle is parallel to the magnetic field then there is no force as shown in Figure B2a. In the simple case of initial particle velocity perpendicular to the field, this force leads to circular motion as illustrated in Figure B2b.

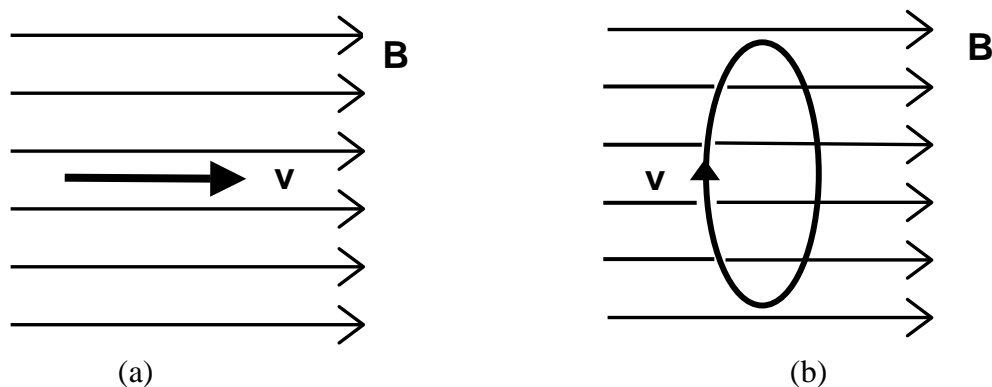

- (a) Charged particles with initial velocities parallel to the external magnetic fields are not affected by the magnetic fields-velocities stay the same in magnitude and in direction.
- (b) Charged particles with initial velocities perpendicular to external uniform magnetic fields are confined to circular paths at constant speeds. (Shown for a positive charge.)

**Figure B2:** Paths charged particles in magnetic fields with velocities parallel or perpendicular to the field

In most cases, however, the velocity may have components parallel and perpendicular to the field as seen in Figure B3a. The component of particle velocity parallel to the magnetic field is unchanged by the external magnetic field. However, the component perpendicular is forced to continually change direction with no change in speed. The combination of drift in the direction of the magnetic field and circles in the perpendicular direction results in the helical motion illustrated in Figure B3b. The circles are stretched out into the helixes.

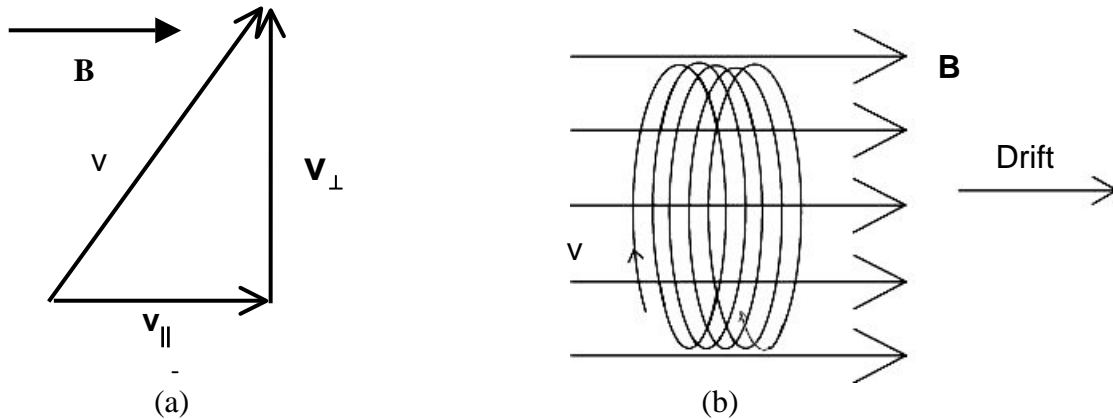

**Figure B3a:** Components of the velocity parallel to the magnetic field ( $\mathbf{v}_{\parallel}$ ) and perpendicular to the magnetic field ( $\mathbf{v}_{\perp}$ )

**Figure B3b:** Helical motion a charged particle in a uniform magnetic field when the particle's velocity has components parallel and perpendicular to the magnetic field.

In summary, a particle with initial velocity perpendicular to a uniform external magnetic field experiences forces that cause circular motion, a particle with initial velocity parallel to the external magnetic field experiences zero magnetic force and a particle with initial velocity having both perpendicular and parallel components moves along screw-like paths known as helix.

The circular motion produced by a magnetic force on a charged particle can be understood by using Newton's Second Law,  $\mathbf{F} = m\mathbf{a}$ . The force exerted by a magnetic field,  $\mathbf{B}$ , on a moving particle of electrical charge,  $q$ , with velocity,  $\mathbf{v}$ , is  $F = qvB$  whenever  $\mathbf{v}$  and  $\mathbf{B}$  are perpendicular. Setting this equal to the particle's mass,  $m$ , times its inward radial acceleration,  $v^2/R$ , where  $R$  is the radius of the circle produced by the magnetic force gives  $qvB = mv^2/R$ . Solving this for  $v/R$  gives  $v/R = qB/m$ , which is independent of the radius of the motion. But  $v/R$  is the angular frequency of the circular motion, that is, it is the rate at which the particle goes around in circles in radians per second. Since in a given magnetic field ( $\mathbf{B}$ ), all particles with the same charge to mass ratio ( $q/m$ ) have the same value of  $v/R$ , all such particles will be forced to turn at the same angular frequency.

In this activity the moving charged particles will be the electrons that go from the source in the back of an oscilloscope to the screen in the front. You will then look at how they interact with magnetic fields from magnets and/or solenoids. Recall that all electrons have the same charge and mass.